



**Fantech**  
Your Ventilation Solutions Company

# KHP Series

## Heat Recovery Ventilator

### IMPORTANT - PLEASE READ THIS MANUAL BEFORE INSTALLING UNIT

**CAUTION** - Before installation, careful consideration must be given to how this system will operate if connected to any other piece of mechanical equipment, i.e. a forced air furnace or air handler, operating at a higher static. After installation, the compatibility of the two pieces of equipment must be confirmed by measuring the airflow's of the Heat Recovery or Energy Recovery Ventilators by using the balancing procedure found in this manual. It is always important to assess how the operation of any HRV/ERV may interact with vented combustion equipment (i.e. Gas Furnaces, Oil Furnaces, Wood Stoves, etc.).

**NEVER** - install a ventilator in a situation where its normal operation, lack of operation or partial failure may result in the backdrafting or improper functioning of vented combustion equipment!!!



Your ventilation system should be installed in conformance with the appropriate provincial or state requirements or in the absence of such requirements with the current edition of the National Building Code, and / or ASHRAE's "good Engineering Practice".

# KHP Models

**KHP 20000 • KHP 30000**

**INSTALLATION, OPERATION AND MAINTENANCE MANUAL**

## The Best Limited Warranty in the Business

- The limited warranty covers normal use. It does not apply to any defects, malfunctions or failures as a result of improper installation, abuse, mishandling, misapplication, fortuitous occurrence or any other circumstances outside Fantech's control.
- Inappropriate installation or maintenance may result in the cancellation of the warranty.
- Any unauthorized work will result in the cancellation of the warranty.
- Fantech is not responsible for any incidental or consequential damages incurred in the use of the ventilation system.
- Fantech is not responsible for providing an authorized service centre near the purchaser or in the general area.
- Fantech reserves the right to supply refurbished parts as replacements.
- Transportation, removal and installation fees are the responsibility of the purchaser.
- The purchaser is responsible to adhering to all codes in effect in his area.
- The warranty is limited to 2 years on parts and 1 years on the motor from the date of purchase, including parts replaced during this time period. If there is no proof of purchase available, the date associated with the serial number will be used for the beginning of the warranty period.

*\* This warranty is the exclusive and only warranty in effect relative to the ventilation system and all other warranties either expressed or implied are invalid. Please fill out the warranty registration and return it within two weeks of purchase or the warranty will be voided.*

# TABLE OF CONTENTS

## INSTALLATION

<b>Safety Instructions .....</b>	<b>3</b>
<b>Installing the Unit .....</b>	<b>4</b>

## OPERATION .....

**6**

## MAINTENANCE .....

**6**

## TROUBLESHOOTING .....

**7**

## TECHNICAL DATA .....

**8**

## TECHNICAL DATA KHP 2000 .....

**9**

## TECHNICAL DATA KHP 3000.....

**10**

NOTE: Some products may not be exactly as illustrated in the Installation, Operation and Maintenance Manual.

Fantech Inc. reserves the right to modify, at any time and without notice, any or all of its products' features, designs, components and specifications, to maintain their technological leadership position.

# INSTALLATION

## SAFETY INSTRUCTIONS

- 1** Do not attempt installing the unit without first reading the entire manual.
- 2** It is always important to determine how the operation of any Heat Recovery Ventilator may interact with vented combustion equipment (i.e. Gas furnaces, Oil furnaces, Wood stoves etc.)
- 3** Never install a Heat Recovery Ventilator in a situation where its normal operation ( including defrost function), lack of operation or partial failure may result in the back drafting or improper functioning of vented combustion equipment.
- 4** If combustible appliances are used in the dwelling, the fresh air hood is to be kept free of obstacles at all times, to prevent improper functioning of these appliances.
- 5** Make sure the outside supply hood is not near a source of contaminated air, which may cause health problems.
- 6** Before opening the access door, either for service or maintenance, make sure that power supply is shut off to prevent injuries due to electrical shock (230v).
- 7** Make sure mounting chains are properly fastened so the unit does not fall, and to prevent any possible injuries.

# INSTALLATION (CON'T)

## Main Power

The main power is to be connected to the main electrical box. Both unit require a single phase, 230 VAC, 20 amps circuit.

## Remote override switch

The override switch needs to be connected to allow the unit to go on high speed. The switch has to be connected to the two pin terminal block inside the main electrical box. This switch will close the contact of a 24 VAC coil inside the electrical box.

## Drain Connection

The condensate drain is connected to the "Exhaust Air out" compartment. The drain line is connected to a 1/2" OD tube. A serpentine loop is recommended on the external drain line.

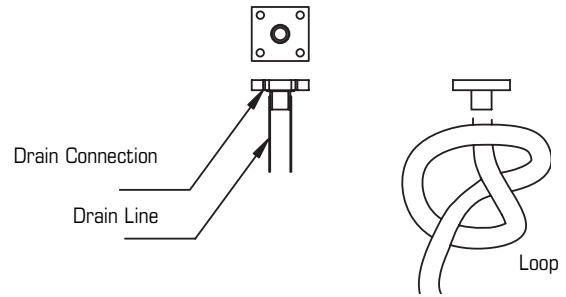

## Mounting Brackets

The mounting bracket, which is already fastened to the unit, is mounted in place using threaded rods. The rods are then connected to the base plates provided with the bracket. The plates have to be at a minimum of 2" from the edge of the rail and in a range of 6" as shown in the drawing below.

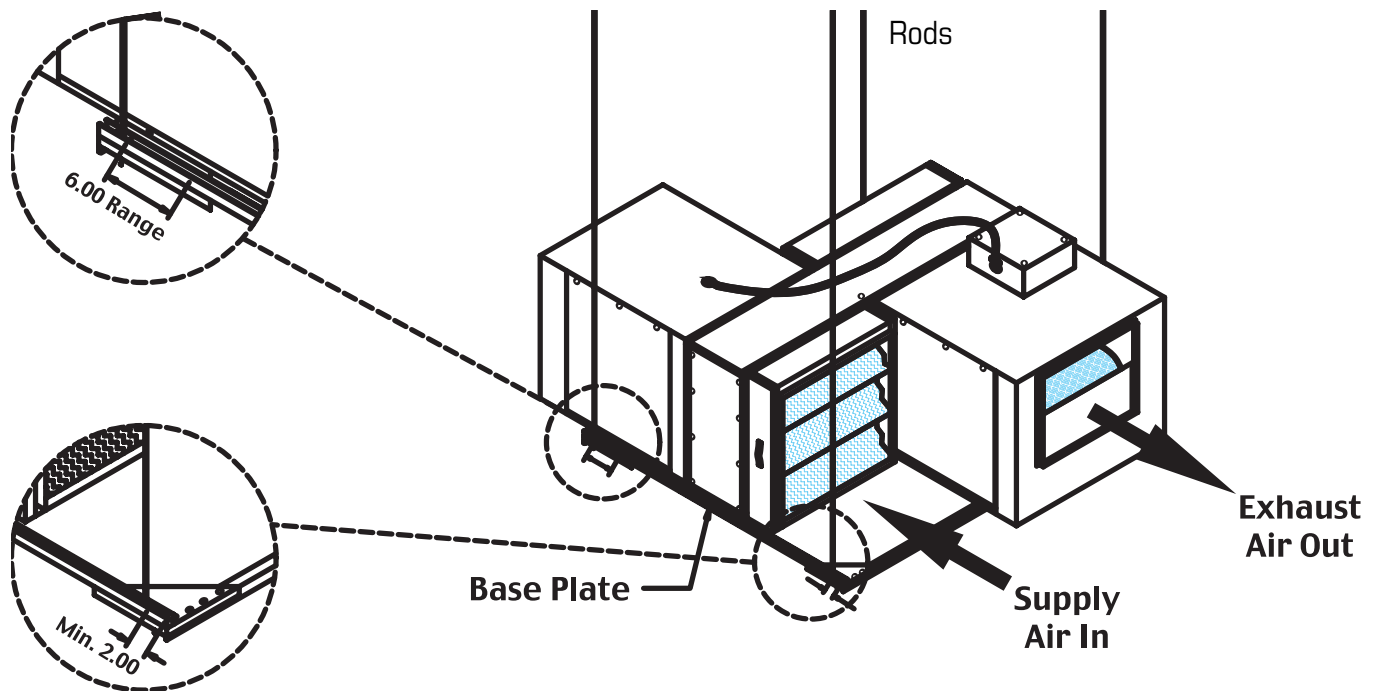

# INSTALLATION (CON'T)

## Winter/Summer Settings

To set the unit in the winter setting, lower the unit 1/2" on the exhaust side from the level line. This will be achieved by adjusting the support nut on the threaded rods.

For the summer setting, you have to rise the unit back to its level line, and then 1/2" more to incline it. The exhaust side should be higher than the supply side on this setting.

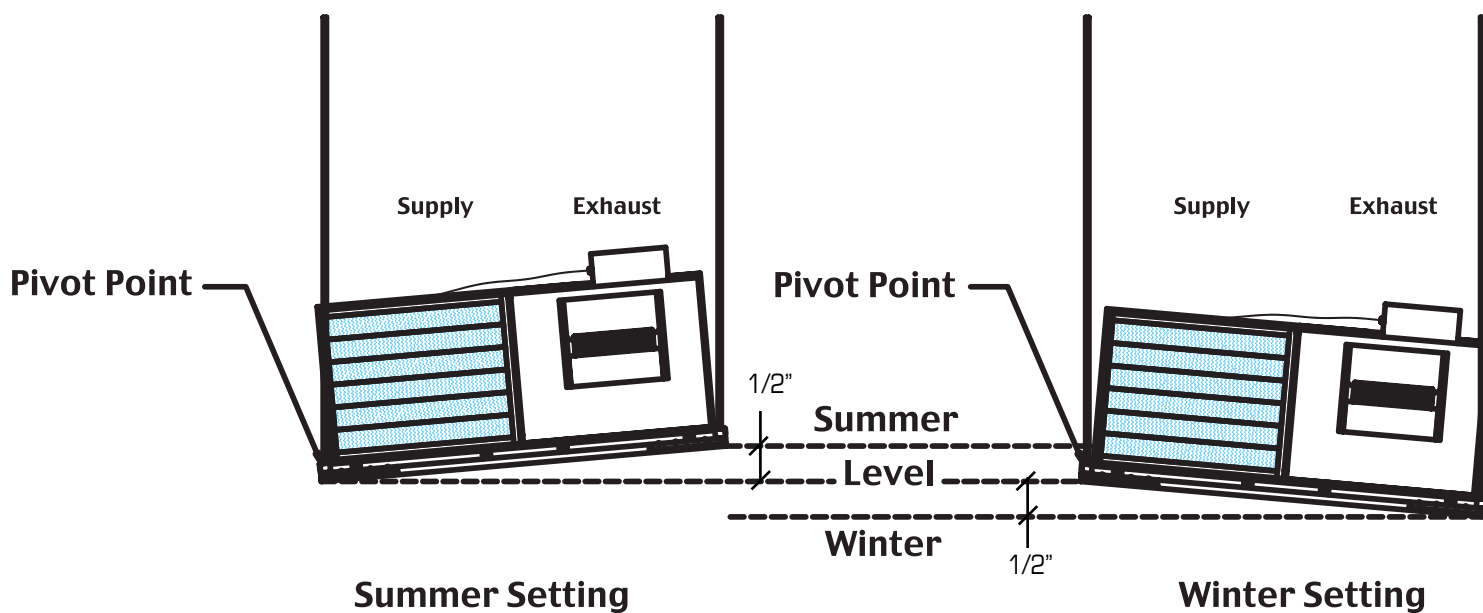

# OPERATION

## Speed Control

The function of the speed controller is to regulate the continuous ventilation rate. This is achieved by a solid state speed control. It permits the operator to set the ventilation at a moderate rate for normal conditions.

## Override Switch

The purpose for the override switch is to activate the ventilation to its maximum capacity. Achieving this contact can be either through a manual switch or a timer control. Voltage for this circuit is 24 VAC.

# MAINTENANCE

## Make sure unit is unplugged before attempting any maintenance work.

### Filters

The filters need to be checked and cleaned every three(3) months. Cleaning the filters can be done with a vacuum cleaner. Filters need to be replaced every 6 months, or sooner depending on the operating and environmental conditions.

### Heat Pipe Core

The heat pipe core needs to be visually checked for cleanliness every six (6) months. If it needs to be cleaned, it is recommended to use commercial condenser coil cleaners.

### Blower Belts

The belts need to be checked for wear and ensure a correct tension is applied. A simple "Rule of Thumb" for checking the belt tension is illustrated on the side. When the belt is grasped as shown, a total deflection of approximately 1" should be easily attained. A visual check of the wear of the belt is also necessary.

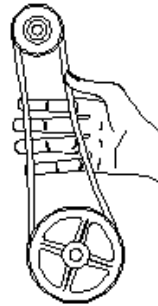

### The drain and drain line

Units with drain lines should have their line and connection checked regularly.

# TROUBLESHOOTING

Problem	Causes	Solutions
Air is too dry	Dehumidistat control is set too low	Increase the desired level of humidity. Change ventilation mode from continuous mode to standby.
Air is too humid	<p>Dehumidistat control is set too high</p> <p>Sudden change in temperature</p> <p>Storing too much wood for heating</p> <p>Dryer vent exhaust is inside home</p> <p>Slow combustion heating only</p> <p>Poor air circulating near windows</p> <p>Basement door is closed</p>	<p>Reduce the desired level of humidity. Combine this step with use of continuous exchange mode.</p> <p>Wait until outside temperature stabilizes (winter). Heating will also improve situation.</p> <p>Store a majority of your wood outside. Even dried, a cord of wood contains more than 20 gallons of water.</p> <p>Arrange outside vent for dryer.</p> <p>Combine with central heating.</p> <p>Open curtains or blinds. Bay or bow windows may require mechanical method.</p> <p>Open the door or install a grill on the door.</p>
Persistent condensation on window	Improper adjustment of control	Reduce the desired level of humidity. Combine this with the use of continuous exchange mode.

# TECHNICAL DATA COMPONENTS

## HEAT PIPE

- Face Area.....4 square feet (KHP 20000)
- Dimensions KHP 20000
- A - 1400 mm (55.125")
- B - 1332 mm (52.4375")
- C - 260 mm (10.25")
- Face Area.....6 square feet (KHP 30000)
- Dimensions KHP 30000
- A - 1778 mm (70.00")
- B - 1713 mm (67.4375")
- C - 457 mm (18.00")
- Rows.....4
- Fins per Inch.....12
- Fin Material.....Aluminum alloy 7072-2
- Fin Design.....Corrugated
- Tube Material.....Copper Alloy 122
- Tube Size.....0.625 inches OD
- Partition Thickness.....14 gauge
- Partition Material.....Galvanized Steel
- End cover Thickness...14 gauge
- End cover Material....Galvanized Steel

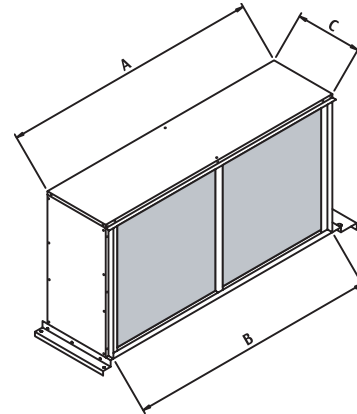

The height is the same for KHP 20000 & KHP 30000 at 37.00

## FILTERS

- Drawer type filter rack throw-away fiberglass filters
- Filter Thickness 1.0 inch Insulated cabinet

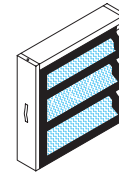

## BLOWERS

- Double inlet / Double width blower belt driven galvanized wheel and housing ball bearing operation temperature range of -54°C (-65°F) to +121°C (+250°F) of airflow capacity of 2000 cfm (KHP 20000) airflow capacity of 3000 cfm (KHP 30000) variable pulleys self-contained insulated cabinet rubber mounted

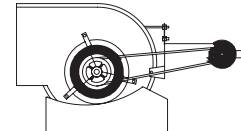

## ELECTRIC MOTORS

- Resilient base / Totally closed air over
- Epoxy enamel finish
- 3/4 horse power, single phase, 115/230 Volts (KHP 20000)
- 1 horse power, single phase, 230 Volts (KHP 30000)
- Start capacitor
- Over load protection
- F56 frame



## UNIT CONTROLS

- Fully variable speed control, automatic frost control, override terminal (24VAC)

## CONDENSATE DRAIN

- 18 gauge galvanized steel drain pan
- Easy hookup to standard 1/2" ID
- Flexible PVC braided hose

# KHP 20000 TECHNICAL DATA PERFORMANCE & DIMENSIONS

## Performance

**External Static Pressure**  
(inches of W.G.)

**Airflow CFM**  
(cubic feet per minute - CFM)

The airflow chart is given at 0.1 interval for fast and precise readings

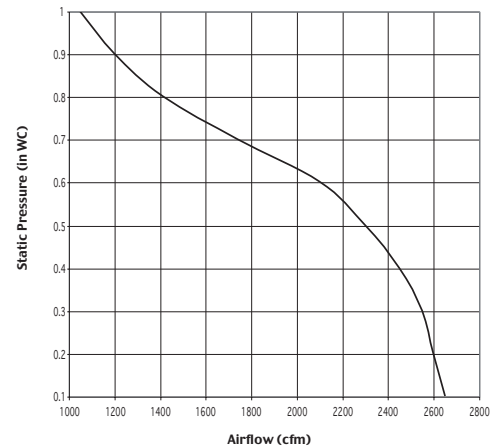

## Dimensions & Weight

Unit Weight 435 pounds

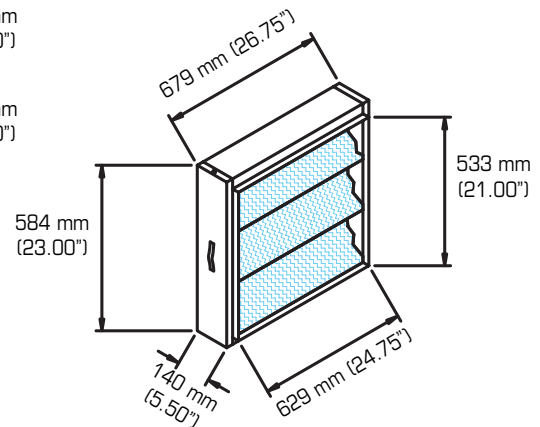
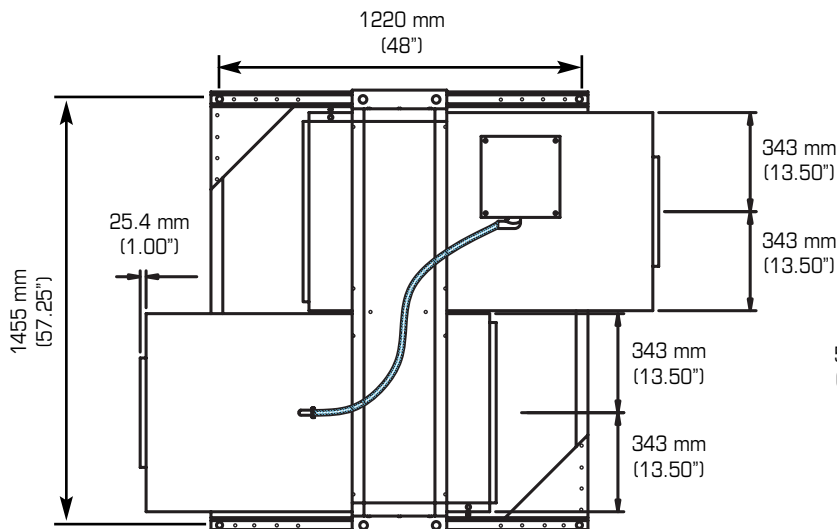
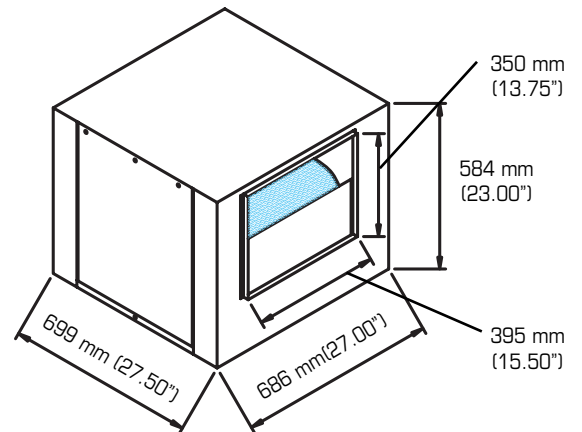
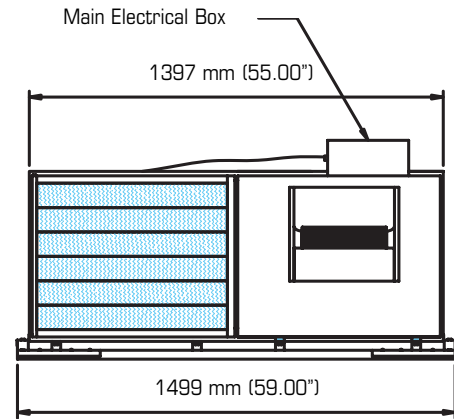
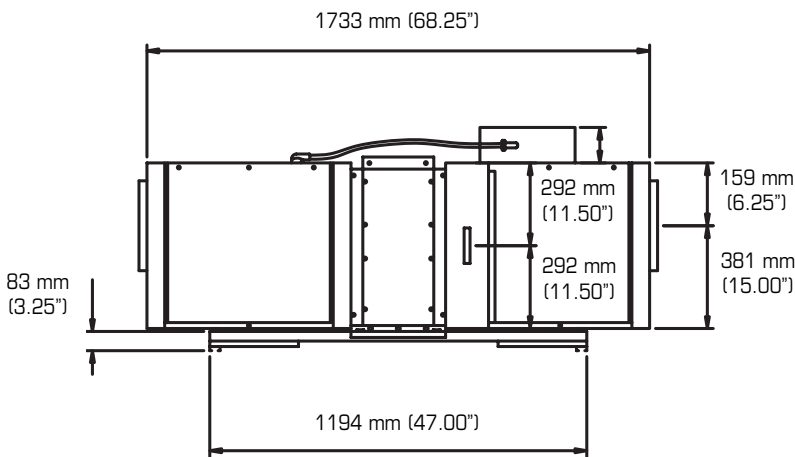

# KHP 30000 TECHNICAL DATA PERFORMANCE & DIMENSIONS

## Performance

### External Static Pressure (inches of W.G.)

### Airflow CFM (cubic feet per minute - CFM)

The airflow chart is given at 0.1 interval for fast and precise readings

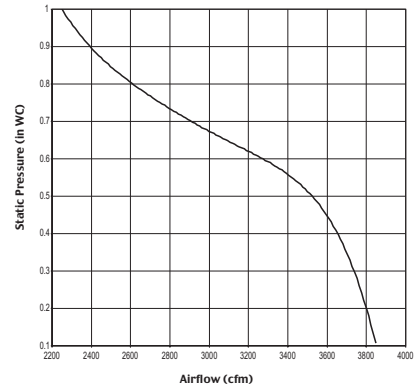

## Dimensions & Weight

Unit Weight 535 pounds

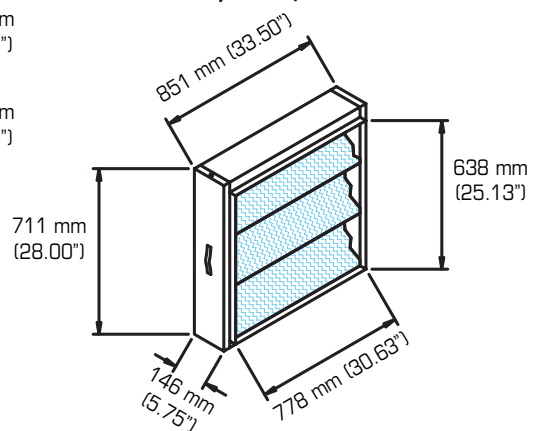
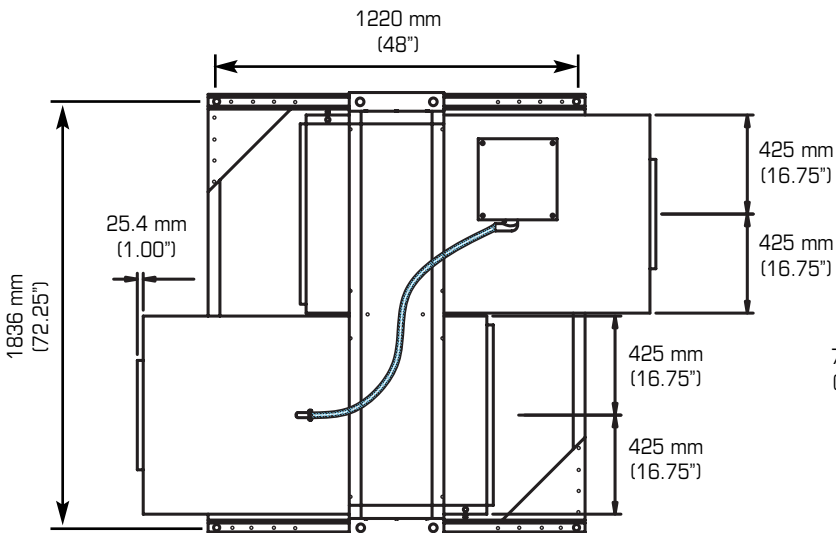
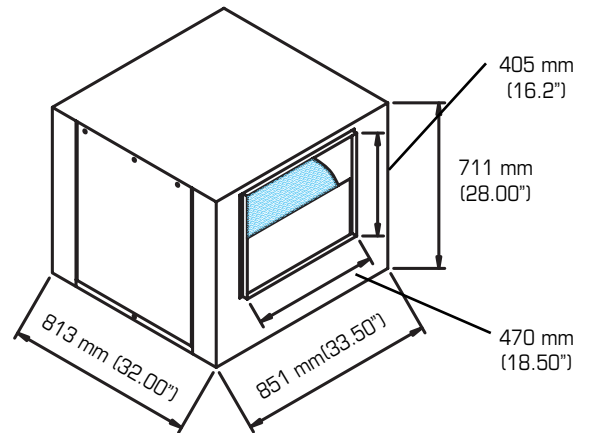
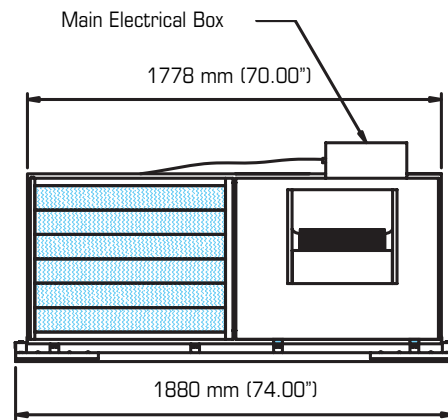
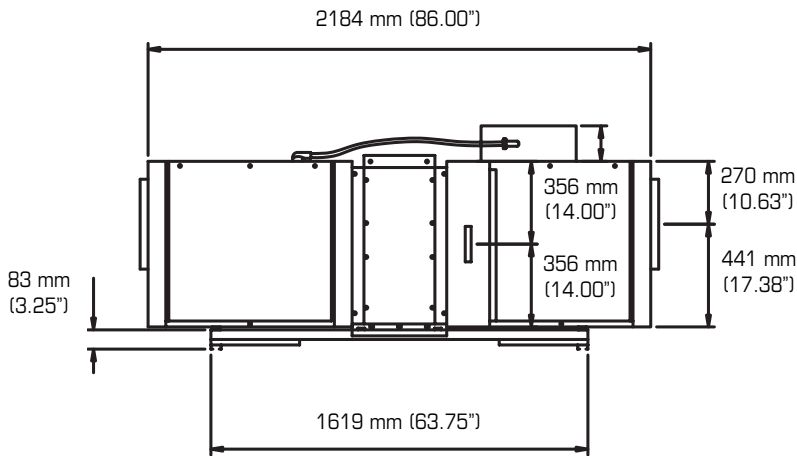





# Fantech

**United States**

1712 Northgate Blvd.,  
Sarasota, FL. 34234  
Phone: 800.747.1762; 941.309.6000  
Fax: 800.487.9915; 941.309.6099  
[www.fantech.net](http://www.fantech.net); [info@fantech.net](mailto:info@fantech.net)

**Canada**

50 Kanalfakt Way,  
Bouctouche, NB E4S 3M5  
Phone: 800.565.3548; 506.743.9500  
Fax: 877.747.8116; 506.743.9600  
[www.fantech.ca](http://www.fantech.ca); [info@fantech.ca](mailto:info@fantech.ca)

Fantech, reserves the right to modify, at any time and without notice, any or all of its products' features, designs, components and specifications to maintain their technological leadership position.

Item #: 401336  
Rev Date: 020205